

# NEW AIR BALANCER EHB-85

**ENDO**  
ENDO KOGYO CO.,LTD.

## High Quality, but Economically Priced!

The EHB-85 AIR BALANCER operates with compressed air to provide both hoist and balancing functions.

- A given weight load can be balanced at "zero gravity"
- Silent operating noise
- Wire rope provides long life and less maintenance cost
- The non-electric air drive is ideal for facilities that require "hazardous duty" (explosion-proof) equipment



### Specifications

#### Body

Model	Air pressure MPa	Max. lifting Capacity kg	Stroke m	Mass kg	Cable dia. mm	Air inlet
EHB-85	0.7	90	1.8	29	4.76	Rc 3/8
	0.6	75				
	0.5	62				
	0.4	50				

#### Hoist Module

Model	Mass kg	Air inlet
MS	2	Rc 3/8
MS-A <sup>1</sup>	2	Rc 3/8

1.-A means "with the Fall Arrest Device"

### Outline EHB-85 with Hoist module

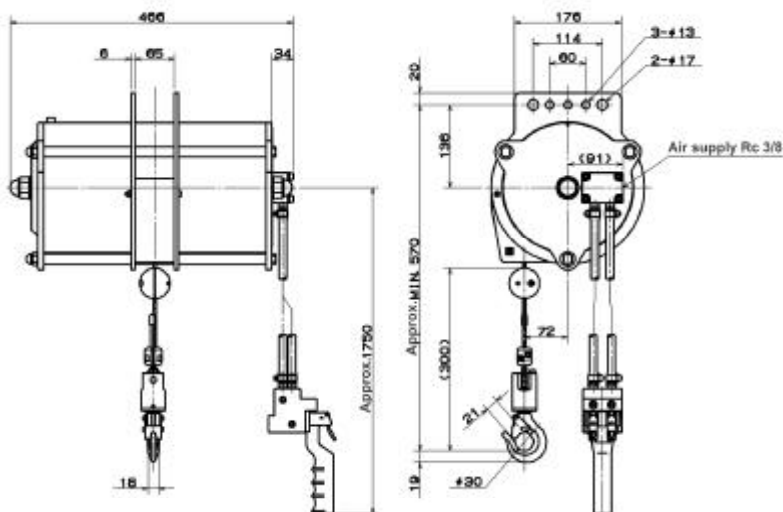

### Options



#### Trolley

P/N
LHP001899
Applicable width
75mm, 100mm



#### Upper hook set

P/N
LHP001900

**ENDO KOGYO CO.,LTD.** <http://www.endo-kogyo.co.jp>

3-14-7, Akibacho, Tsubame, Niigata, Japan

TEL. +81-256-62-5133 FAX. +81-256-62-5772